



Steam Boiler

Operating instructions and maintenance enclosed
Thoroughly read and understand instructions
Always leave this manual with stove owner

Follow the instructions within this manual. If instructions are not followed, a fire may result causing property damage, personal injury, or even death.

A carbon monoxide detector has been supplied with your stove. You must plug it in.

Danger risk of fire or explosion. Do not burn garbage, gasoline, drain oil, or other flammable liquids. Do not use chemicals or fluids to start fire.

Burn rice or buckwheat anthracite coal only

Stoves surfaces may be hot while in operation. Keep children away. Do not touch during operation

Do not connect this unit to a chimney flue serving another appliance.

Follow all local building and Zoning ordinances

KEYSTOKER STEAM BOILER INSTALLATION INSTRUCTIONS

Through these instructions we will try to guide you on a step by step procedure for installing, adjusting and operating of your new KEYSTOKER stoker boiler unit.

Selection of location. Keystoker boilers are available with fire door on the right or left side. When you stand at the stoker end of the boiler and look directly over top of boiler toward stack end, you may choose to have a fire door on the right or left side of boiler. Selecting a position to make this door accessible is important. When door side must be placed toward a wall, 30" clearance is recommended for easy fire and ash door access. Clearance from wall at stack end should be 18" to permit removal of water heating coil if necessary. Clearance on blank and hopper sides should be 6".

Setting up boiler. Place boiler in desired position. We strongly recommend placing steel shims or bricks under each corner of boiler to allow an air space, to prevent moisture from accumulating and rusting base of boiler. Using a level, plumb stoker end of the boiler, adding steel shims as necessary to plumb the stoker end of the boiler. Failure to do this will change pitch on stoker unit and may have adverse effects when burning coal. Again with level, check top of boiler from side to side, adding shims as necessary to level boiler. Do not place shims completely under boiler. Allow 1" to 2" of shims to extend out from under the boiler. Shims will then be used as a base to rest insulated jacket upon.

Supply & Return piping system. The top of your boiler has at least 4 openings. The largest opening is the feed line to your radiation. A steam supply header must be installed with an equalizer tied into the condensate return line (See Diagram pg9).

You may use either of the large openings on the bottom of the stack end of the boiler as your condensate return. **A HARTFORD LOOP MUST BE INSTALLED.** The condensate return must be tied into the equalizer pipe coming from the steam header. When tying condensate return into equalizer pipe use a close nipple to tie into tee. **Condensate return line must be piped in 2" below lowest operating water level.** (see diagram pg9).

Install a boiler drain valve in the other large opening at bottom of boiler. (See Diagram pg 7).

Boiler fill. The boiler fill must be tied into condensate return piping. We recommend using a McDonnell & Miller Uni-match Automatic water fill (not included with boiler).

Domestic water piping. Refer to Installation Diagram Pg 6; install 1/2" male adaptors in both fittings on domestic water coil. Install a 1/2" black plug in the 1/2" fittings on top of boiler by the domestic hot water coil. **NOTE:** Before proceeding with connections and piping of domestic water, **INSTALL** stack end of insulated steel jacket **NOW**. Then you may proceed with completion of domestic piping and installation of necessary valves. (See Diagram Pg 10).

Install a domestic water mixing valve, we recommend a Honeywell AM-1 series not included with boiler install as per manufactures instructions (See Diagram Pg 10).

KEYSTOKER STEAM BOILER INSTALLATION INSTRUCTIONS

Install a PH 5 expansion tank on the domestic mixed water line as per manufactures instructions (See Diagram Pg 10).

Installation and piping of accessories: A 1” 2lb AMSE approved relief valve must be installed in 1” fitting on top of boiler, turning discharge to the side and hard pipe it to 3” above floor (See Diagram Pg 9).

Install Steam pressure gauge and PA 401 steam pressure limit control in either of the two ½” boiler fittings on the top of the boiler. Bush from ½” to ¼” then thread in ¼” pig tail pipe with a ¼” tee on top and pipe in steam gauge and Pa 401. (see Diagram pg 9).

Install immersion well for low water cut off, in ¾” fitting on side of boiler above fire door in lower hole closest to unit end of boiler (see diagram pg 9).

Install immersion well for 4006A, in ¾” fitting on side of boiler above fire door in upper hole (see diagram pg 9).

Place fire door into boiler opening and secure by tightening screws in frame of fire door. Seal fire door with high temp. silicone or furnace cement. Install spring handle on fire door handle by bending spring handle open and put it through hole in handle on fire door and squeezing it closed.

Jacket installation: Install hopper end of jacket, then blank side, then fire door side, secure with #8 x 1 sheet metal screws provided. Install jacket top and secure with #8 x 3/8 sheet metal screws.

Stoker installation: Stoker units are shipped entirely assembled. Lift stoker into opening, bottom of a stoker has a ¼” rod welded in place which must go inside the stoker opening. Place a thick smear of furnace cement or high temperature silicone on flange of stoker and tilt into place, securing with 3/8 x 1 ¼ machine screws, washers, and nuts as provided. Remove shipping screw from gear box.

Set hopper into place. The hopper bottom should lap over stoker throat approximately 1”. Since one hopper is use for several size stokers, it may be necessary to trim the opening. Bend flange down to fit inside throat of stoker – be sure mechanism is free to operate.

Control installation and electrical wiring: Install 4006A into its well being careful not to kink the thin capillary tube. Install low water cutoff onto its well. Screw timer & RA 89 relay to jacket next to the 4006A (see diagram p 9).

Your stoker must be on its own circuit. From main breaker to boiler use 12-2 wire with ground on a 20 amp breaker. Follow wiring diagram and any applicable UL and local code

KEYSTOKER STEAM BOILER INSTALLATION INSTRUCTIONS

Stack pipe and draft control installation: Stack pipe may now be connected from boiler to chimney, using as few elbows as possible. If stack pipe must be reduced in size, reduce stack at thimble. It is important to run full size stack from boiler to chimney thimble. Install barometric draft controls in first full section of stack closest to boiler. Follow instructions packed with draft control, making sure the draft control bearing are level and face of draft control is perpendicular to floor. Stack pipe must be 18" from any combustible.

Initial start up: Fill system by opening boiler fill valve. Turn power switch on and watch sight glass large stoker motor will start when operating level is reached. Automatic will stop filling boiler when stoker motor starts. Fill valve must remain in the normally open position.

Open valve supplying water to domestic hot water coil, this valve must remain in the normally open position.

Starting coal fire: DO NOT USE ACCELERANT SUCH AS: as gasoline, litter fluid, or kerosene, etc. Use dry coal only. Put coal in hopper. By reaching through fire door, pull coal down to cover entire grate. Crush several charcoal briquettes into smaller pieces, crumble newspaper and dig it through the coal, so it touches the grate. Lay charcoal on top of newspaper. Turn switch on. When charcoal turns red, place a few hands full of coal on top of charcoal. If fire moves toward bottom of grate before fire is established, coal feed can be slowed down by turning red nut CCW or by flipping feed bolt to a sideward position. (Part #22 on Unit specification sheet)

After starting coal fire: Allow stove and chimney to warm up. Insert draft gauge through pre-drilled hole in upper portion of fire door. Open air shutter (located on bottom of scroll between stoker motor and gear box about 1/2"). Then with stoker motor running and feeding coal adjust the barometric damper until draft gauge reads (-.02). If draft is less than a (-.02) draft with the barometric damper closed you must close the air shutter (between gear box & stoker motor) a little and recheck. Repeat until you obtain a (-.02) draft. If the draft is higher than (-.02) you must adjust the barometric draft regulator. Move the weight on barometric regulator left or right to obtain the (-.02) Recheck the draft until you obtain a (-.02).

Initial coal feed: Advance red nut all the way forward. Then turn it counter clockwise 11 or 12 turns if burning rice coal, if burning buckwheat coal turn coal feed, back 9 or 10 turns. When boiler is running for about an hour under full load grates should have about 2" of dead ash on them before falling into the ash pan.

Coal Feed: (RED NUT) To increase coal feed and fire size, turn red nut (CW).
To reduce coal feed and fire size, turn red nut (CCW).

KEYSTOKER STEAM BOILER INSTALLATION INSTRUCTIONS

After a fire has been established and all fresh coal laying on grate has burned, its time to set coal feed. When stoker unit is running steady (approximately 1 hour) fire bed should extend downward to lower portion of grate with approximately 2" of ash on bottom of grate . When thermostat is satisfied, stoker unit will shut off. When stoker only runs during timing cycle, the fire bed will gradually shrink to approximately 3" to 4" of red coals. After proper length of fire bed is obtained, coal feed is set.

As prices of fuel continues to increase –**KEYSTOKER** – continues to improve and make its product more fuel efficient.

To obtain a more complete burn out of coal, a small secondary blower motor was attached to the stoker unit. **THIS MOTOR IS DESIGNED FOR CONTINUOUS RUN.**

When large stoker motor is running on demand, small blower will assist with combustion and heat output, by producing a more intense and hotter fire. When demand cycle is completed, large stoker motor will shut off, and small secondary motor will continue to run. This will cause the coal that is already on the grate to burn, rather than to allow coal to smolder and die out in an unburned condition. This will achieve a cleaner ash, and allow more heat to be produced and absorbed into heating system.

During summer operation, the small combustion motor will force a small amount of air through grates at all times, which will cause the ash to become like powder. It also prevents the fire from going out. At the same time, it reduces the size of fire bed to approximately 1 ½" to 2" which will prevent boiler water from becoming overheated.

Proper sizing of fire is obtained by turning red nut on feed control arm. Clockwise (CW) for more coal feed and Counterclockwise (CCW) for less coal feed.

Location and final placement for red nut will be determined by size of coal you purchase. For rice coal, red nut might be turned down 12 turns for maximum setting, whereas for buckwheat coal, red nut might only be turned down 10 turns from maximum setting.

During winter operation, hot coals should never be pushed off end of grate. This indicated that coal feed needs to be reduced (CCW) or if during winter operation; fire bed is too small, turn red nut (CW).

After coal feed adjustment is completed, if during summer, the water is too hot...**DO NOT ADJUST COAL FEED.** Reduce timer only. If fire goes out...**DO NOT ADJUST COAL FEED.** Increase timer only.

KEYSTOKER STEAM BOILER INSTALLATION INSTRUCTIONS

Setting Timer: Is factory set. Yellow clock wheel makes one revolution every 30 minutes. Each clip sticking out of yellow wheel will cause stoker to run approximately 15 seconds when clip touches switch. Timer setting will vary depending upon chimney draft. Normal timing cycle is about one minute on, 14 minutes off (4 clips side by side). Four clips at 0 and 4 clips at 15. If timing cycle needs to be increased, add 1 or 2 clips to both groups of clips. Or in case, of chimney having poor draft, clips may be placed in 3 groups at number 0-10 & 20. If boiler, is making steam when thermostat is not calling for heat remove one clip from each group not closer than a 24 hour period.

Cleaning and Servicing: Turn power supply off before getting started. Annually it is most important to clean boiler and stack pipe at least once per year. Scrape down inside walls of boiler and baffle to remove soot or dirt from all surfaces. Remove and clean stack pipe, clean base of chimney. Examine chimney for blockage with a mirror. Brush off barometric damper. Reinstall stack pipe and seal at thimble.

Remove secondary blower, by removing two screws in its flange and lifting it out of its mounting base. Then remove two screws in the cleanout plate. Push vacuum hose in under grates and suck out fly ash. Assemble cleanout plate and secondary blower in reverse order of disassembly.

If boiler is going to be shut down for summer, boiler must be cleaned as soon as it is shut down. We recommend putting a lit light bulb in the boiler while it is not in operation. You need to empty hopper and lubricate all moving stoker parts.

Oil stoker motor and circulator (if necessary) with SAE 20 non detergent motor oil.

Oil gear box with 90 weight gear oil. Oil level should not be less than $\frac{1}{2}$ full and no more than $\frac{3}{4}$ full.

Using a chisel or brick, scrape grates smooth. Then rub grates and inside of side rails with sand paper to remove impurities that melt and fastened themselves to grate. Holes in grates may be cleaned by using an 1/8" punch.

Boiler must be drained and rust inhibitor put back in every year. Per rust inhibitor manufactures instructions.

KEYSTOKER STEAM BOILER INSTALLATION INSTRUCTIONS

1. Stoker Body
2. Side Rail Left K-2C
3. Side Rail Right K-1C
4. Grate K-15-1-L
5. Grate K-15-2-L
6. Grate K-15-3-L
7. Grate K-15-L-4
8. Motor
9. Blower Rotor
10. Bearing K-19
11. Throat Strap K-18
12. Pusher Bar Drive Yolk K-8-BC
13. Pusher Bar K-9-BC
14. Pusher Bar Drive Shaft
15. Bearing K-17
16. Feed Crank K-7
17. Feed Assembly Connector K-6
18. Feed Arm Nut
19. Feed Arm Adjustment Nut
20. Feed Latch K-12
21. Feed Spring
22. Feed Bolt
23. Drive Wheel K-5
24. Gearbox K-14
25. Coupling
26. Secondary Combustion Blower

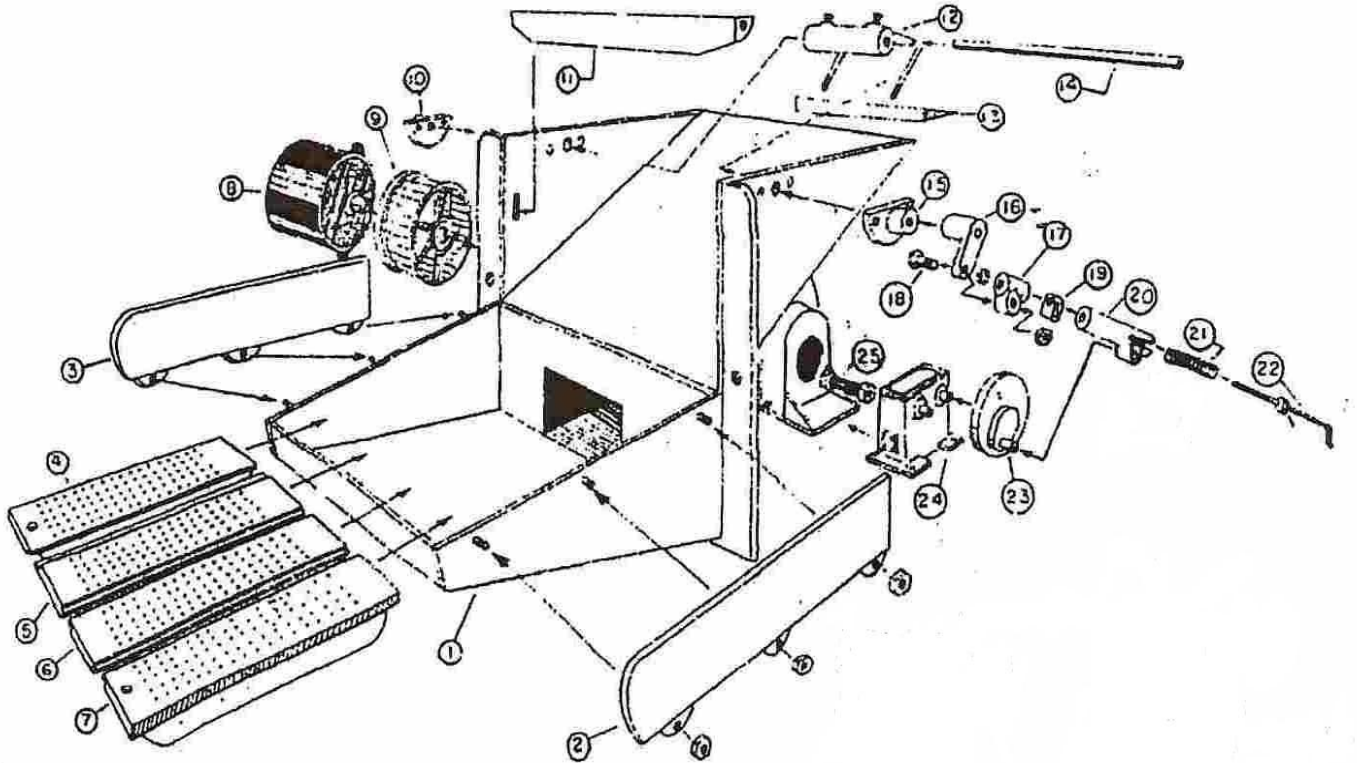

KEYSTOKER STEAM BOILER INSTALLATION INSTRUCTIONS

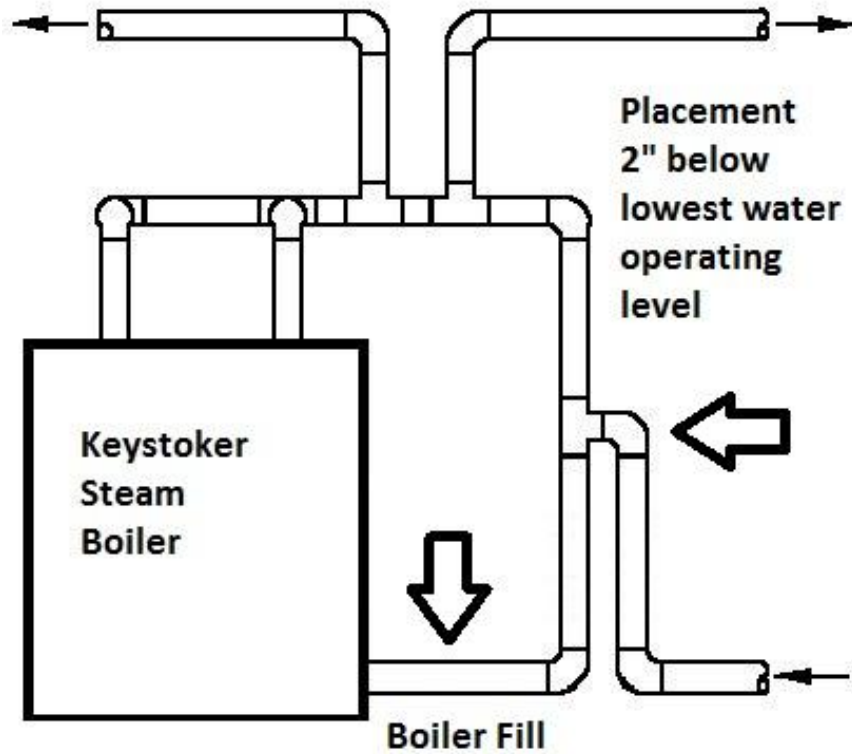
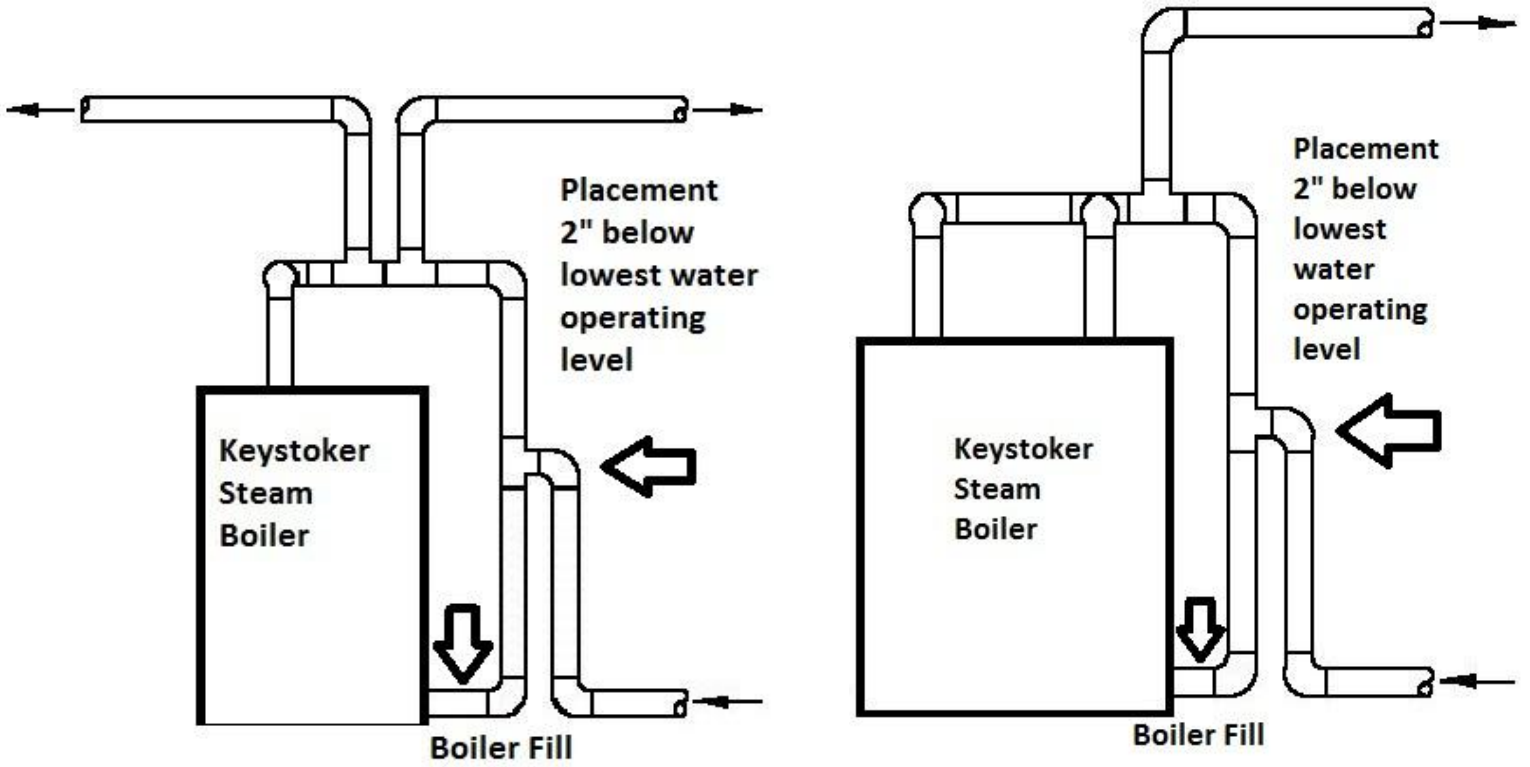

KEYSTOKER STEAM BOILER INSTALLATION INSTRUCTIONS

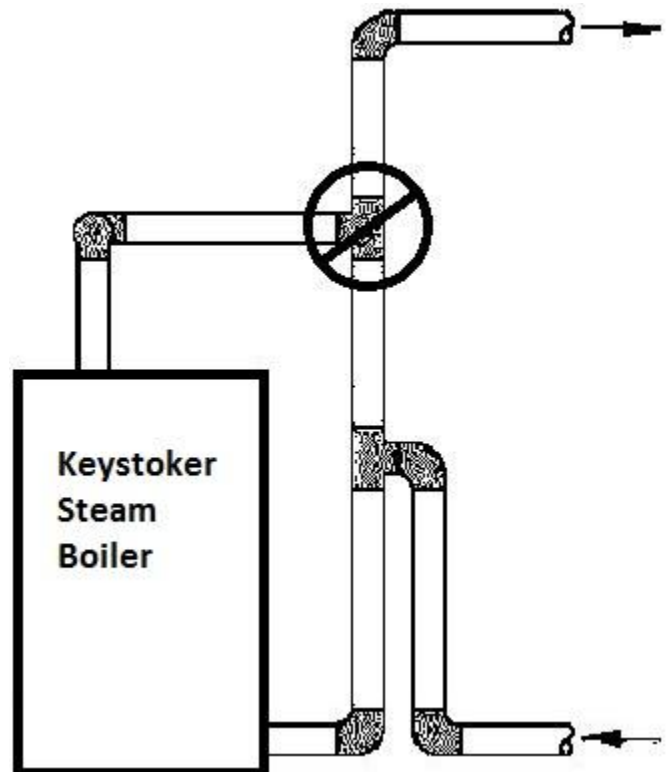
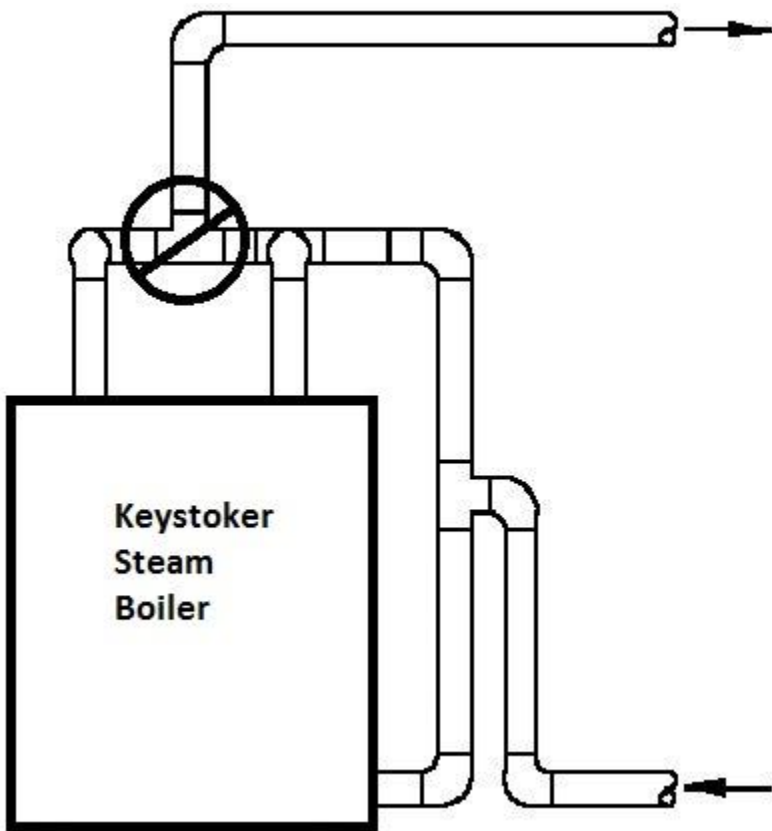
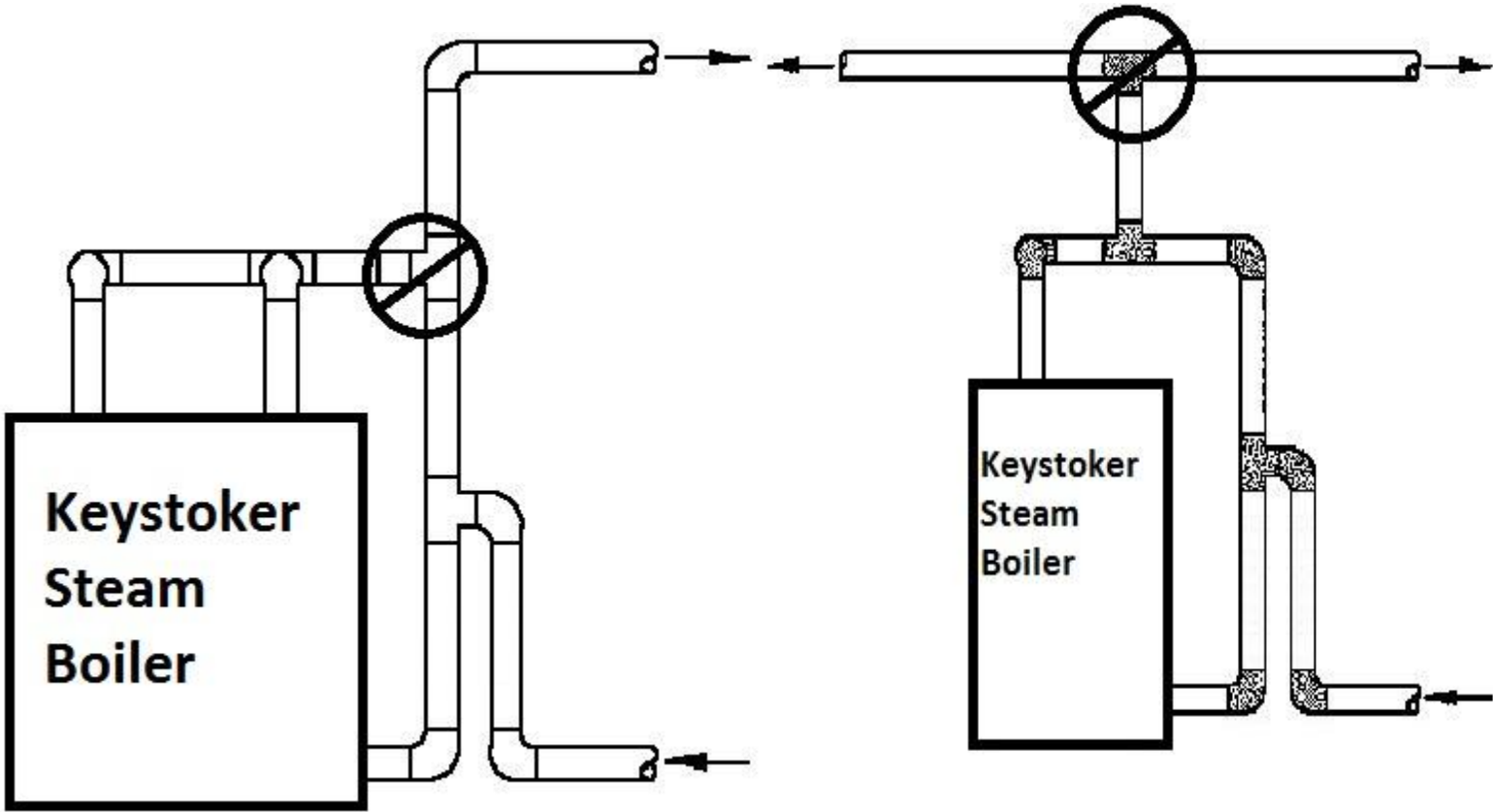

KEYSTOKER STEAM BOILER INSTALLATION INSTRUCTIONS

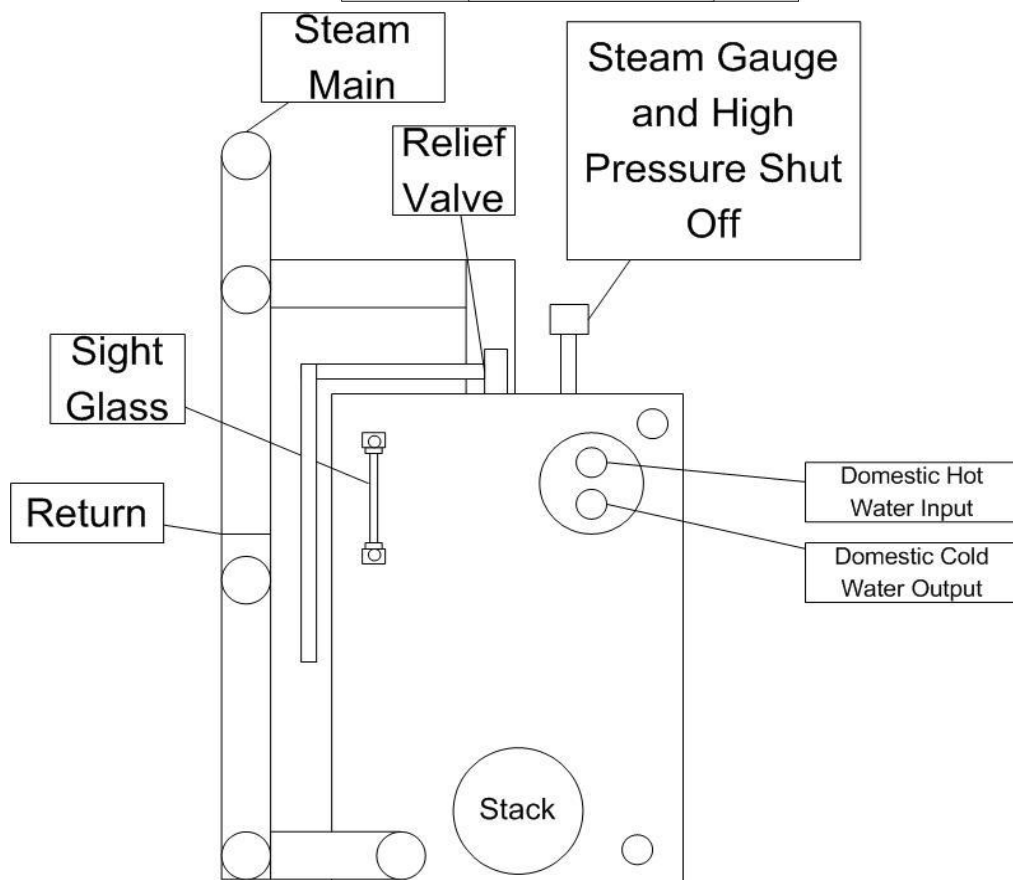
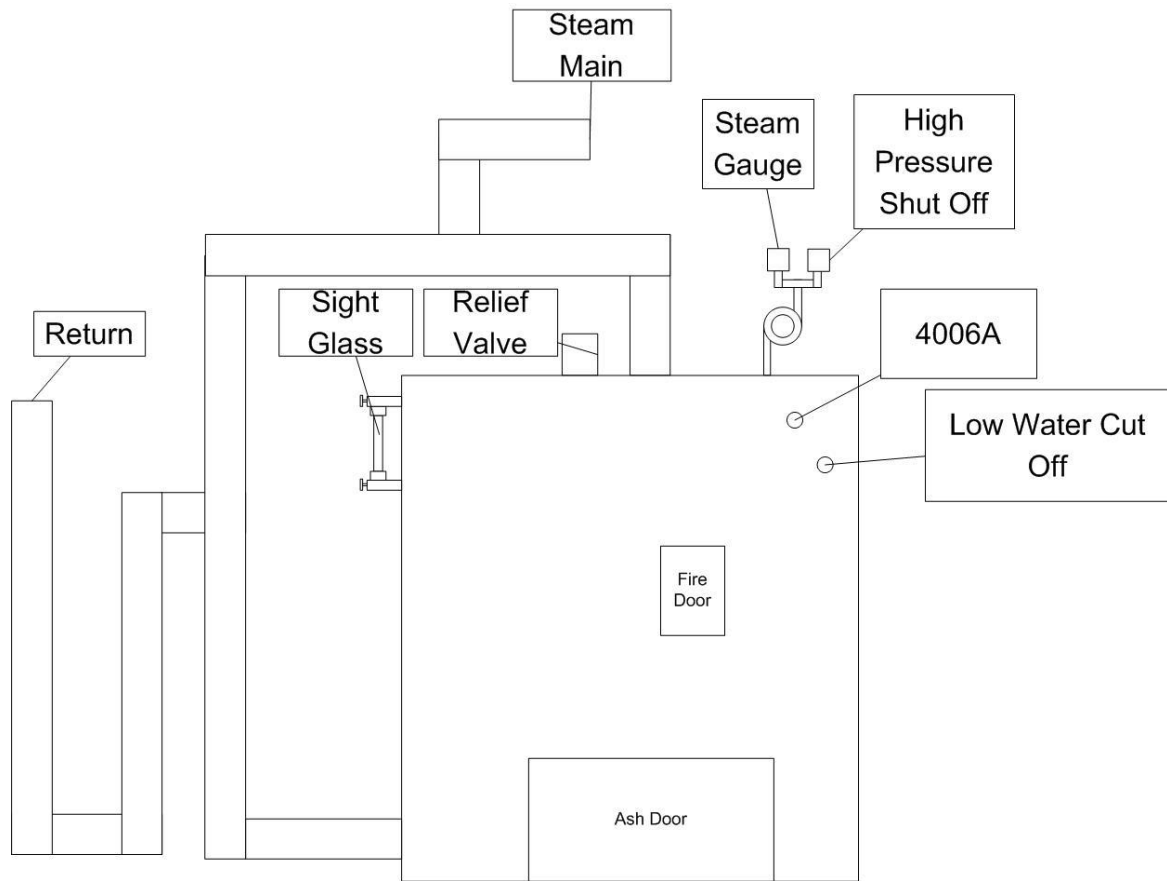

KEYSTOKER STEAM BOILER INSTALLATION INSTRUCTIONS

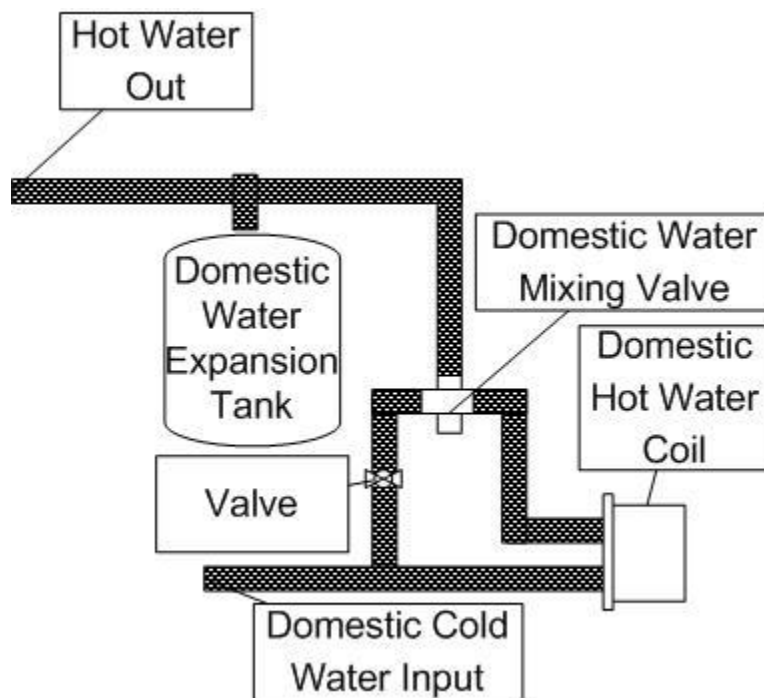
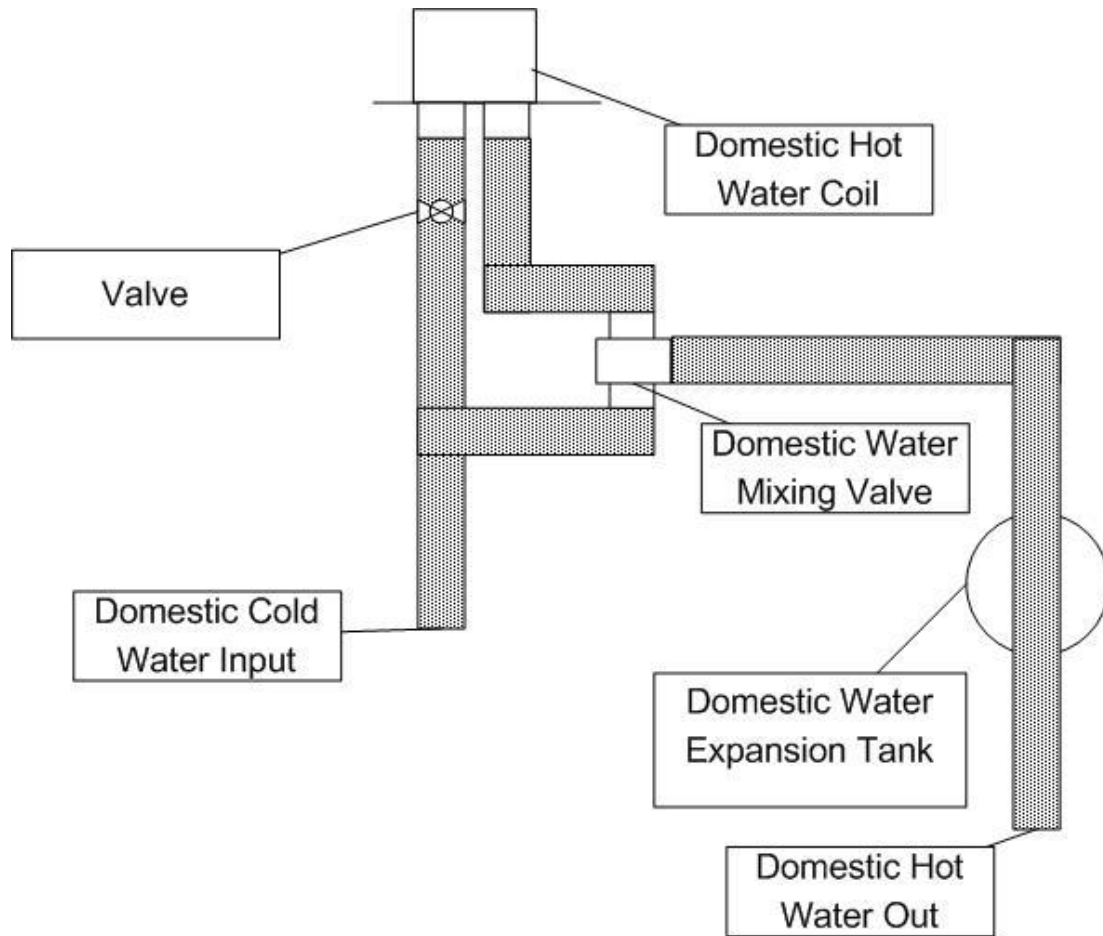

KEYSTOKER STEAM BOILER INSTALLATION INSTRUCTIONS

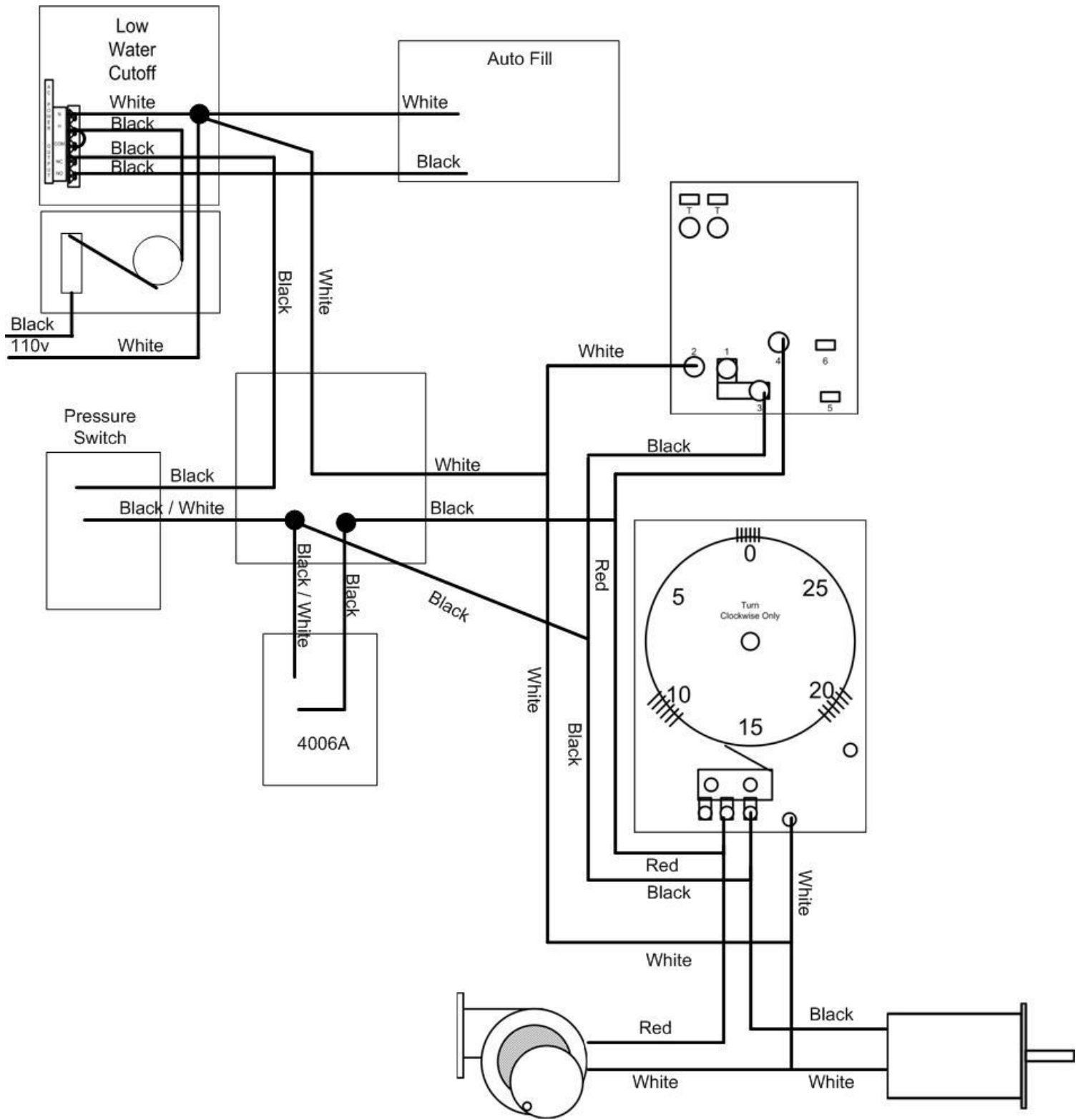

TROUBLE SHOOTING HINTS

PROBLEM	POSSIBLE CAUSE	REMEDY
Stoker doesn't run	Main circuit breaker tripped	Reset
	Main fuse blown	Replace
	Fuse on stoker blown	Replace
	Motor out on reset	Press rest button on motor
	Lo water level (steam)	Fill boiler to proper water level
Stoker motor goes out on reset	Obstruction in throat of stoker	Empty hopper and clear
	Feed mechanism tight or corroded	Empty hopper and free-soaking with penetrating oil-Use dry coal to prevent reoccurrence.
	Motor or gear box defective	Replace

Stoker runs but doesn't feed coal	Feed nut backed off too far.	Increase feed-see preceding instructions.
	Obstruction in throat of stoker.	Empty hopper and remove obstruction.
	Feed mechanism tight or corroded	Empty hopper –free- use dry coal to prevent reoccurrence.
	Broken or slipping coupling	Replace
	Defective gearbox	Replace
	Feed mechanism out of adjustment	Throat bar height to be 1-3/4" to 2" (Part #11). Pusher bar (Part #12) to be approximately 3/4" behind the face (flat part) of throat bar when in its most forward position with feed nut (Part #19)

Steam Checklist

Charcoal
Thermostat
Carbon monoxide detector
PA 404 Pressure Controller
Water Gauge
1" 2 Psi Safety Valve
Steam Gauge
4006A $\frac{3}{4}$ Well
Well
2 Hopper Bolts
2 $\frac{5}{16}$ Bolts
6 $\frac{3}{8}$ Washers
4 Hopper Washers
Spring handle
2 $\frac{3}{8}$ nuts
Fire door
Damper
Control
Manual
Warranty card